

ALFA 85

REGULATION

- Touch screen regulation
- Fully equipped with temperature and pressure sensors
- 4 control alternatives: controller, BMS (via ModBUS RTU), service software, WiTouch
- Possibility to connect 2 controllers thanks to dual ModBUS
- Monozone CAV or DCV, multizone VAV or DCV ventilation
- Integrated anti-freeze protection
- Integrated time switch (week or day)
- Automatic detection of heating / cooling (DX, C/O)
- Possibility of connecting air quality sensors (CO₂ sensor, RH sensor, PIR motion sensor and other sensors with output 0-10V)
- Boost, freecooling regimes



WITOUCH

- Complete control system with many extending functions
- Possibility to connect and to control up to 32 products (96 with additional extender)
- Remote control via internet with possibility to connect any smart device
- Android - main controller with WiTouch application (iOS, Android, Windows, Linux - via web browser)
- Graphic display of current operating situation and history savings
- Remote support of the 2VV technical operators via internet
- Wireless communication available



SOFTWARE SUPPORT

- Service software
- Selection program Choose&GO



Do you need more information?
Contact us on our website or via email!

www.2vv.cz
2vv@2vv.cz



ALFA 85
driving wheel of your ventilation

ALFA 85

Wide and flexible range of highly efficient heat recovery units for indoor/outdoor installations designed for commercial application such as **offices, coffee bars, restaurants and sport facilities.**

MODEL RANGE

- 8 sizes of vertical version with air flows **700 - 7,500 m³/h**
- 6 sizes of version with upper outlets with air flows **700 - 4,500 m³/h**



VERTICAL

700; 1 000; 1 500; 2 000; 3 000;
4 500; 5 500; 7 500 m³/h



UPPER

700; 1 000; 1 500; 2 000;
3 000; 4 500 m³/h



PERFORMANCE CHARACTERISTICS

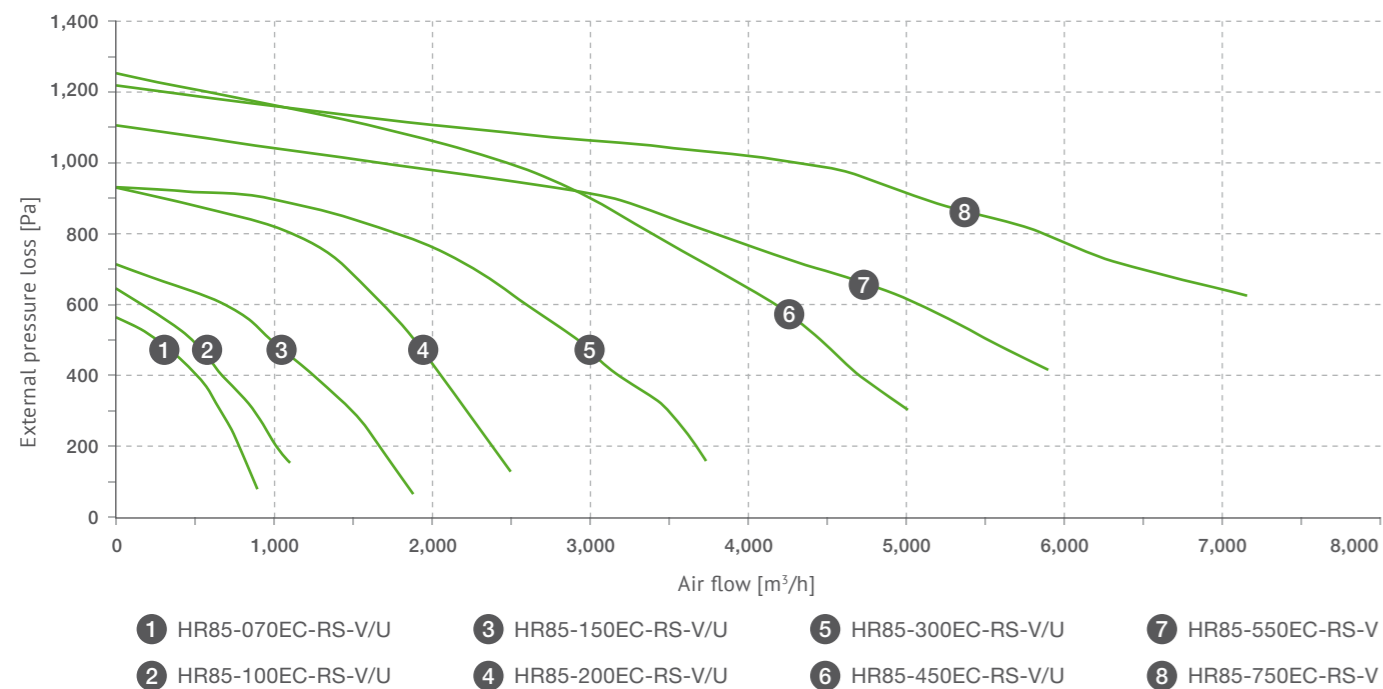

ROTARY HEAT EXCHANGER

- High efficiency of heat recovery up to 85 %
- Humidity recovery
- Automatic regulation of the rotation
- Step motor ensuring high reliability
- Suitable for extreme low temperatures



HEAT RECOVERY EFFICIENCY

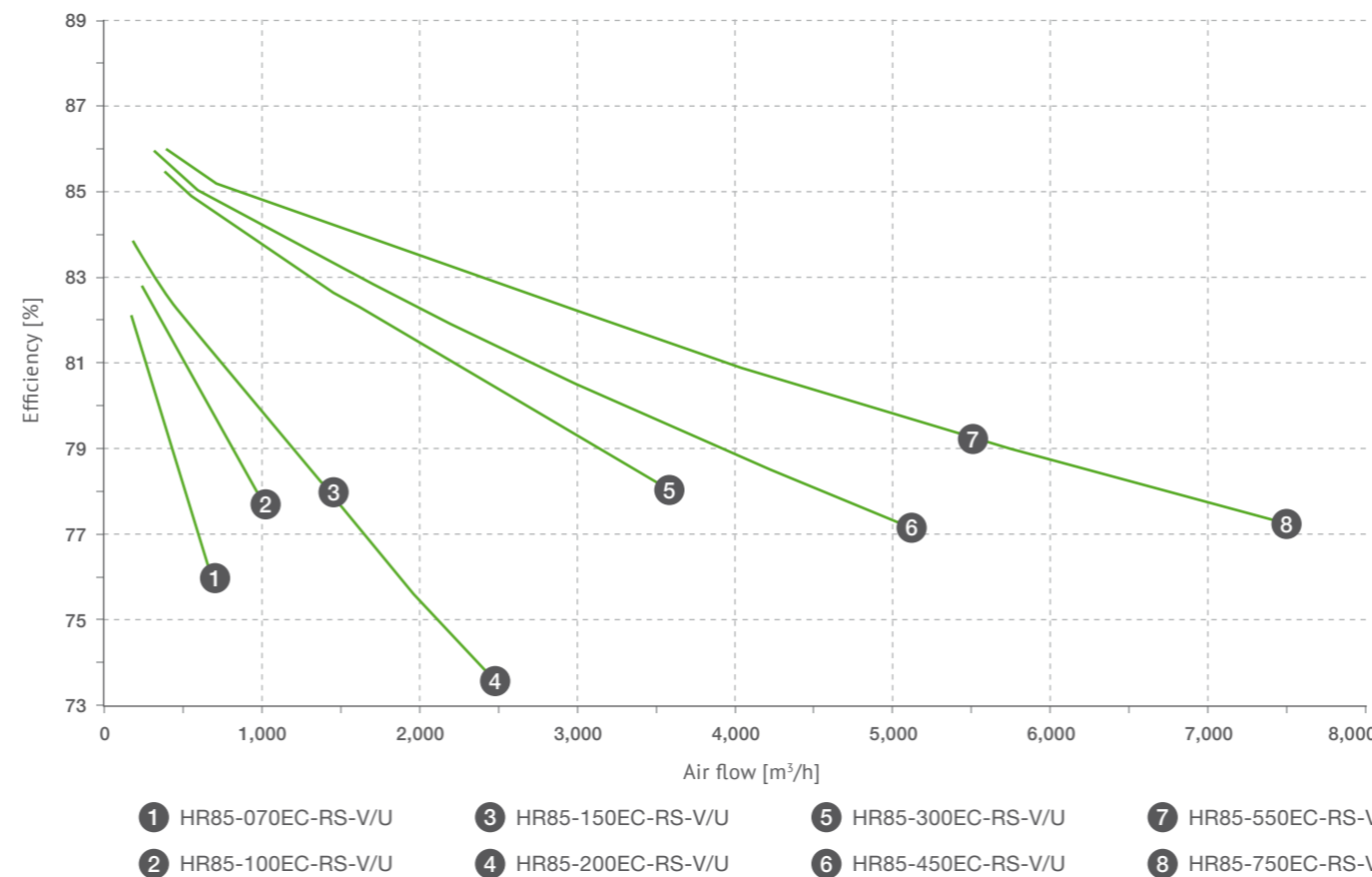

ALFA 85

EC FANS

- Radial fans with backward curved blades (EBM)
- High efficiency
- Low SFP
- Silent operation
- Fluent regulation of the fan speed

AFTERHEATER/COOLER

- Integrated afterheater/cooler: electric, hot water (heating only), water change-over, DX coil

CONSTRUCTION

- Sandwich panels insulated with rockwool (50 mm)
- Construction without thermal bridges
- Suitable for indoor and outdoor installation down to -20 °C
- Compact (up to 2,000 m³/h) or modular (from 3,000 m³/h)
- Left and right service access
- Easy to service = segmentally divided access door (not more than 25 kg)

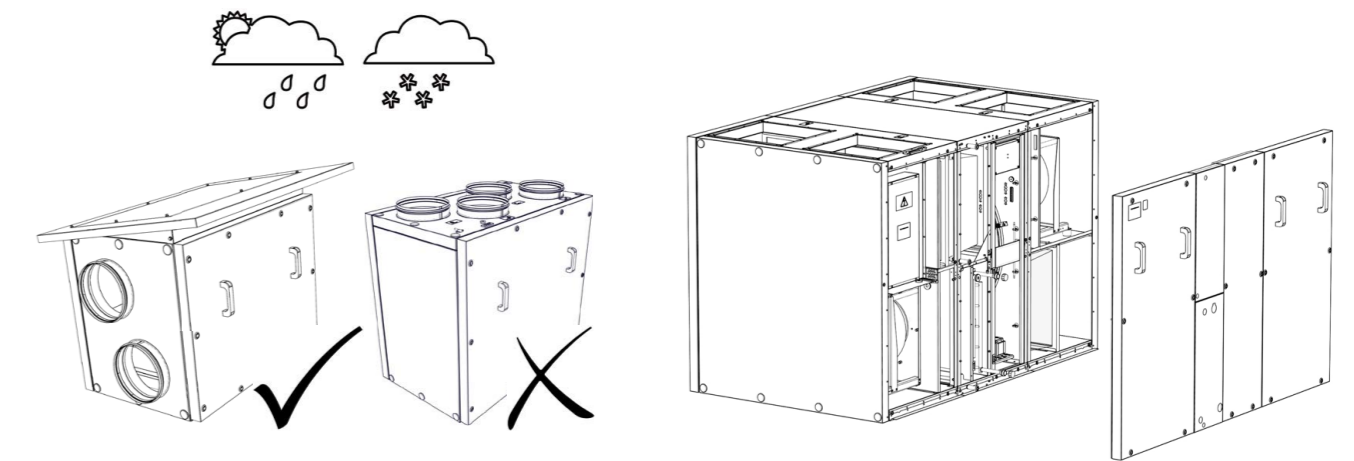

FILTERS

- Filter class M5 on supply to the room and exhaust from the room
- Filter class F7 available as optional accessories
- Easy exchange
- High durability
- Automatic clogged filter signalization